

■ DESCRIPTION

The DM-880-EB is a professional, low input impedance, hyper-cardioid and hand held dynamic microphone. The microphone is suitable for general use and vocal application. The microphone body is rigidly constructed of metal die-cast and designed to reduce switching and handling noise.

■ SPECIFICATIONS

Type	Moving coil microphone
Directivity	Hyper-cardioid
Frequency Response	70 – 17,000 Hz
Sensitivity	-52 dB ±3 dB (0 dB=1V/Pa, 1kHz)
Rated Impedance	250 Ω, balanced
Talk Switch	Short-off circuit type, slide switch
Terminal	XLR-3 type
Finish	Body: Die-cast zinc, black, paint Head: Steel, black, paint
Dimensions	Ø54 X 174 mm (without connection cable)
Weight	344g (without connection cable)
Accessory	Connection cable (XLR female – phone plug, unbalanced, 5m) ...1 Microphone holder (5 / 8") ...1

■ APPEARANCE

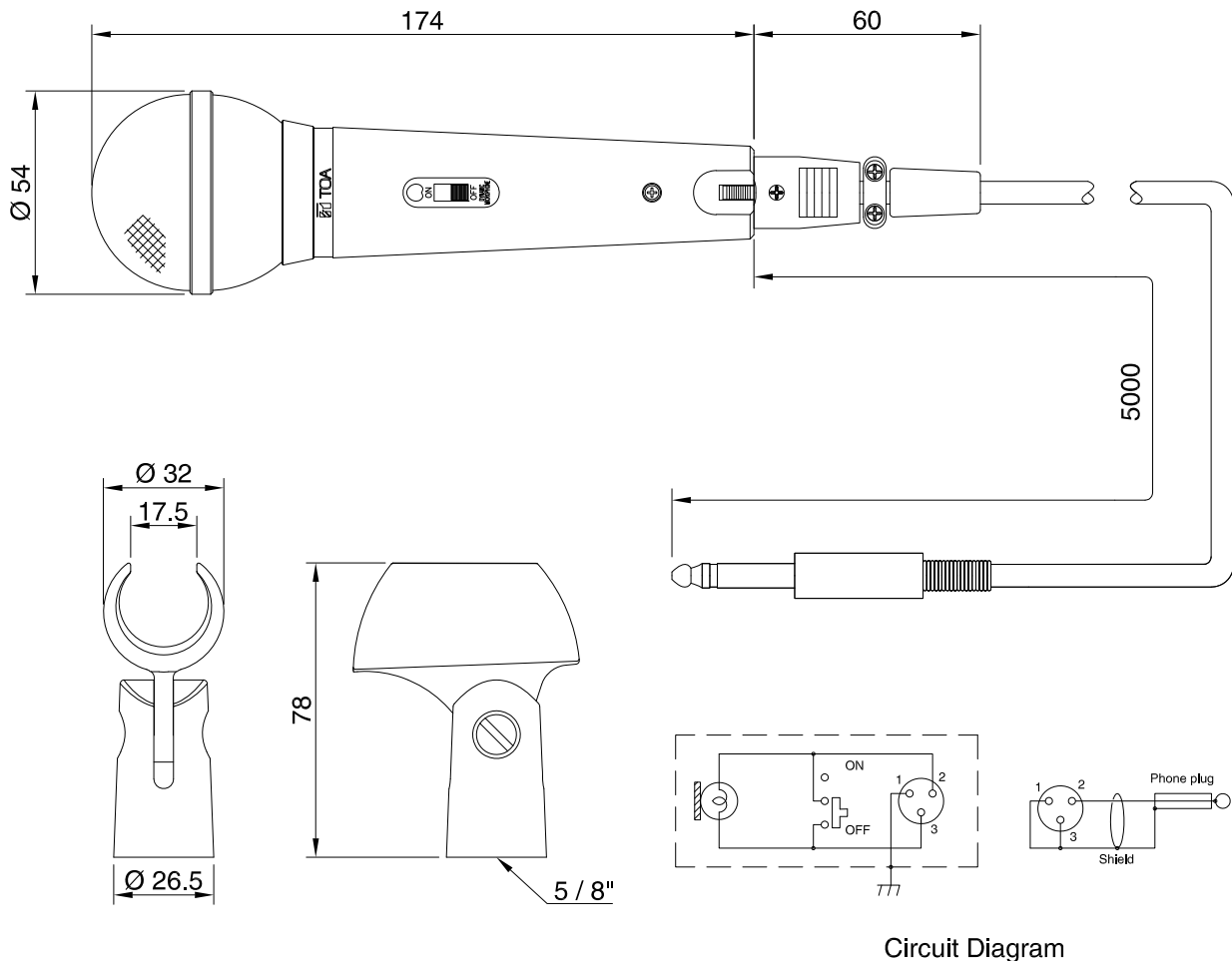

Circuit Diagram

UNIT: mm SCALE: 1/2